



RAM METER INC.®

Instrument Sales & Service Center
Electronic Development & Manufacturing
FOUNDED 1936

Mounting CT's

CT's are generally located in the main breaker panel or in branch distribution panels where space is always at a premium. Since CT's do not have to be installed 90 degrees to the conductor run (the conductors can go through the CT at any angle) they are generally held in place with plastic tie wraps. CT's with mounting feet are available if appearance is important and there is enough room to accommodate this type of mounting arrangement.

Installing CT's

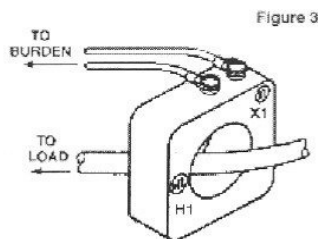

Figure 3

Window type CT's should be mounted with the H1 side of the window towards the power source. The X1 secondary terminal is the polarity terminal (Figure 3). The polarity marks of a current transformer indicate that when a primary current enters at the polarity mark (H1) of the primary, a current in phase with the primary current and proportional to it in magnitude will leave the polarity terminal of the secondary (X1).

If a CT test switch is used, the switch must have a "make-before-break" contact pattern to assure that the CT is not open-circuited during transition.

Normally CT's should not be installed on "Hot" services. The power should be disconnected when the CT's are installed. Many times this is not possible because of critical loads such as computers, laboratories, etc. that cannot be shut down. Split core CT's should not be installed on "Hot" uninsulated bus bars under any conditions.

On existing cable installations where the monitoring point is not close to a cable end, small ring core CT's can be shunt installed on #8 cable or smaller by using Hot Tap insulation piercing connectors similar to those made by 3M. A parallel shunt through the CT is connected to the power cable as shown in (Figure 4). Tape all bare ends.

Check your work before leaving the installation. Make sure all connections are tight and the installation is neat.

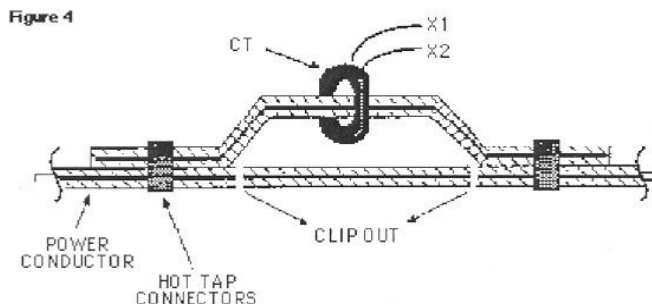

Figure 4

CAUTION: Never open-circuit a CT secondary while the primary is energized. High crest voltages may occur across the open secondary circuit. To avoid personal injury or equipment damage, the secondary must always be short-circuited or connected to a burden. **NOTE:** A buzzing transformer is an indication of an open secondary.

RAM METER INC. - 1903 BARRETT DRIVE - TROY, MI 48084

PH: 1-800-446-4035 - FAX: (248) 362-1818

Visit us on-line at WWW.RAMMETER.COM or contact us at SALES@RAMMETER.COM