

# MODEL 2742

## 3-Phase Over/Under Current Monitor

- Monitors over or under current
- Fail-safe design
- Automatic or manual reset
- Adjustable trip delay timer
- For use on motors, pumps, conveyors, etc.

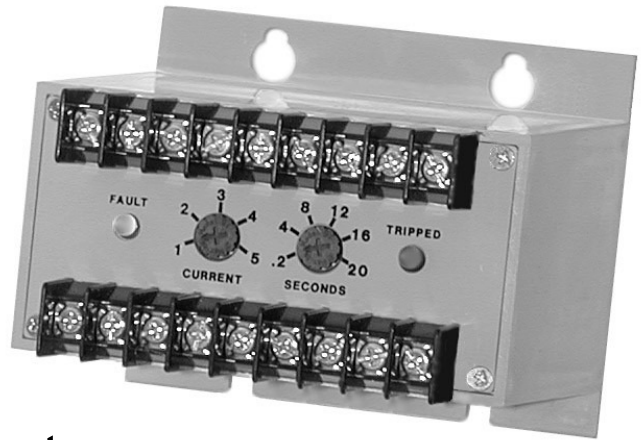

### DESCRIPTION

The Model 2742 3-Phase Over/Under Current Monitor is designed to monitor the current level of a three-phase line or to compare the currents of three single-phase lines.

The Model 2742 is factory-set as an over-current monitor; that is, if one or more current inputs rises above the trip level, the internal relay will de-energize. Adding a wire between the UNDER CURRENT terminals on the case will cause the Model 2742 to sense a decrease of one or more current inputs.

An adjustable trip delay of 0.2 to 20 seconds will prevent nuisance tripping. The current trip point is adjustable from 1 to 5 amps, and matching current transformers are available to extend the current range of the monitor.

The Model 2742 will automatically reset when the current fault is corrected. An external manual reset can be added by installing a normally closed switch between the terminals marked RESET.

### TYPICAL APPLICATION

Over-current; auto reset;  $\leq 5$  amps

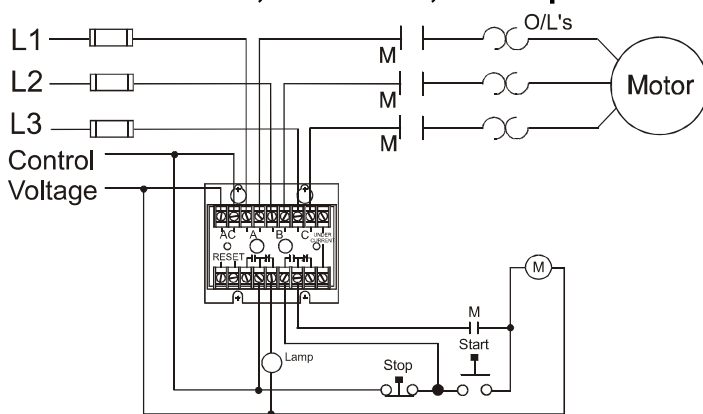

*Shows No Power Applied*

### SPECIFICATIONS

Model	2742-24	2742-115	2742-220
Supply voltage	20-28VAC	100-130VAC	190-250VAC
Max supply voltage	30V	140V	260V
Power consumption	1.5 Watts max.		
Transient protection	2500 VRMS for 10ms		
Frequency range	50 - 400Hz		
Input current	1-5 amps $\pm 5\%$		
Max. input current	40 amps for 2 sec		
Current range	1-5 amps $\pm 5\%$		
Trip delay	0.2 to 20 sec $\pm 5\%$		
Dead band	4% max.		
Contact rating	DPDT 10A at 240VAC resistive		
Expected relay life	Mech: 10 million operations Elec: 100,000 ops at rated load		
Operating temperature	-20° to +131° F		
Enclosure material	ABS plastic		
Weight	1 lb. 5.9 oz.		

### DIMENSIONS

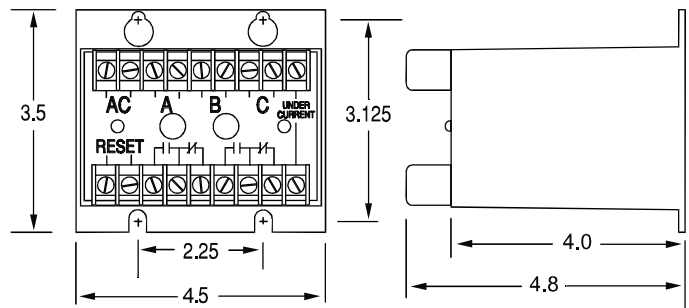

Telephone: Main - (918) 438-1220

Sales - (800) 862-2875

Fax: (918) 437-7584

E-mail: sales@time-mark.com

Internet: http://www.time-mark.com



**TIME MARK**  
CORPORATION

11440 East Pine Street  
Tulsa, Oklahoma 74116

11/2011

© 2011 TIME MARK CORPORATION

TIME MARK is a division of  AEMT, Inc.

# MODEL 2742

# 3-Phase Over/Under Current Monitor

READ ALL INSTRUCTIONS BEFORE INSTALLING, OPERATING OR SERVICING THIS DEVICE.  
KEEP THIS DATA SHEET FOR FUTURE REFERENCE.

## GENERAL SAFETY

POTENTIALLY HAZARDOUS VOLTAGES ARE PRESENT AT THE TERMINALS OF THE MODEL 2742.  
ALL ELECTRICAL POWER SHOULD BE REMOVED WHEN CONNECTING OR DISCONNECTING WIRING.  
THIS DEVICE SHOULD BE INSTALLED AND SERVICED BY QUALIFIED PERSONNEL.

## Installation Instructions

### INSTALLATION

Mount the Model 2742 in a suitable enclosure.

If the current to be monitored is 5 amps or less, break and connect each wire to the three inputs of the Model 2742 (see TYPICAL APPLICATION on front page). **Observe polarity.**

If the current to be monitored is greater than 5 amps, install a current transformer on the line. Connect the secondary leads of the CT to the Model 2742 terminals (see TYPICAL APPLICATION on this page). **Observe polarity.**

Connect the operating supply voltage to the AC input terminals.

Connect the load control wiring to the appropriate terminals. **For most motor control applications**, use the normally open contact(s), which will close when the current is within the acceptable range. **For alarm applications**, use the normally closed contact(s). Refer to the diagram on this page.

If a manual reset is desired, connect a normally closed push-button across the RESET terminals (see figure 1). If under-current sensing is desired, add a jumper connection (see figure 2).

Turn on the supply voltage. The contacts should transfer and neither indicator light should be lit.

### ADJUSTMENT PROCEDURE

Set the SECONDS adjustment to the required amount of delay. If the desired current trip level is known, set the CURRENT adjustment to that point. A slight adjustment up or down may be necessary to allow for tolerance inaccuracies.

**NOTE: If the manual reset is used, press and hold the reset button during this step.** Usually a trip is desired only if the current changes from the present nominal. To calibrate for this turn the SECONDS adjustment to the maximum delay. Turn the CURRENT adjustment up or down until the FAULT indicator lights. Turn the CURRENT adjustment back, until the FAULT light just goes out. Reset the SECONDS delay to the previous setting.

### TYPICAL APPLICATION

Over-current; auto reset;  $\geq 5$  amps

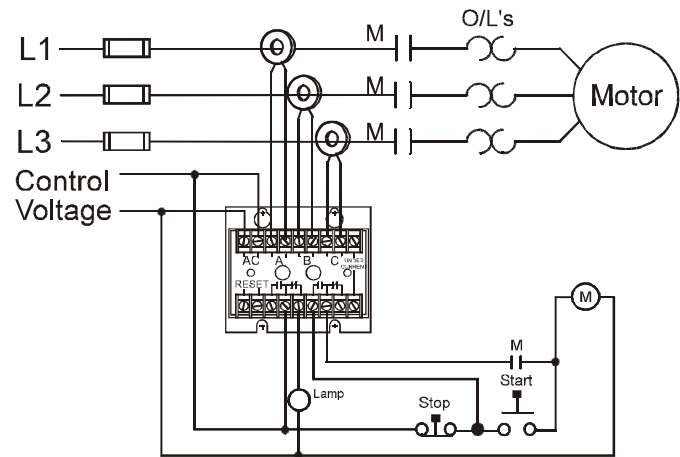

Shows No Power Applied

figure 1

MANUAL RESET

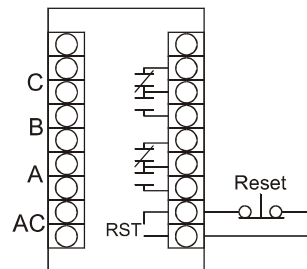
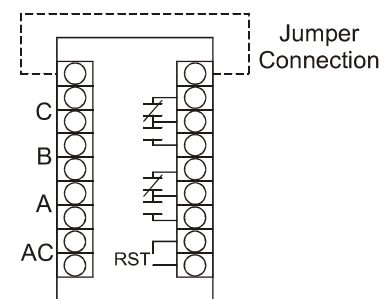

figure 2

UNDER-CURRENT SENSING



### WARRANTY

This product is warranted to be free from defects in materials and workmanship for one year. Should this device fail to operate, we will repair it for one year from the date of manufacture. For complete warranty details, see the *Terms and Conditions of Sales* page in the front section of the Time Mark catalog or contact Time Mark at 1-800-862-2875.

Telephone: Main - (918) 438-1220  
Sales - (800) 862-2875  
Fax: (918) 437-7584

E-mail: sales@time-mark.com  
Internet: http://www.time-mark.com



**TIME MARK**  
CORPORATION

11440 East Pine Street  
Tulsa, Oklahoma 74116

11/2011  
© 2011 TIME MARK CORPORATION

TIME MARK is a division of  AEMT, Inc.